

Super-Slim Type Low-Noise Duct Fan (With Filter)

超薄型静音管道风机 (带过滤网)



新品
NEW

CE

The Super-Slim Type Low-Noise Duct Fan is an ideal equipment for ventilation in hospital, house, villas, office, conference rooms, shopping malls, hotel, restaurants and other public places. It can be efficiently used with connection to ducts for air supply, perfectly keeping the indoor air clean and fresh.

Silver Ion HEPA-filter, it can highly traps and eliminates airborne bacteria, germs and mold bacteria, also help to capture 99.9% of the PM2.5 particles and remove unpleasant odors.

超薄型静音管道风机是现代居住场所必备的通风设备, 它能有效地进行送风, 令室内空气清新、干净, 适用于医院、家庭、别墅、办公楼、会议室、商场、宾馆、酒楼或其它公共场所等。

采用银离子高效过滤网, 能有效除菌和去除附着性气味, 抑制细菌和霉菌等病菌的繁殖, 并去除99.9%的细微悬浮粒子PM2.5。

External Dimensions 外形尺寸图

DGT10-24H, DGT15-34H, DGT15-45H,
DGT15-55H, DGT20-56H, DGT20-56J

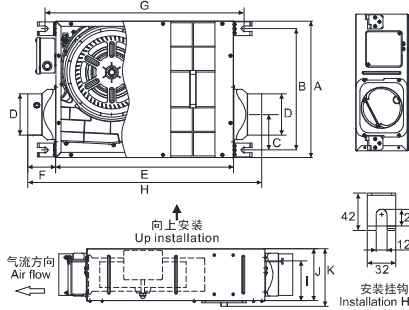

DGT25-56H, DGT25-66H, DGT25-76H

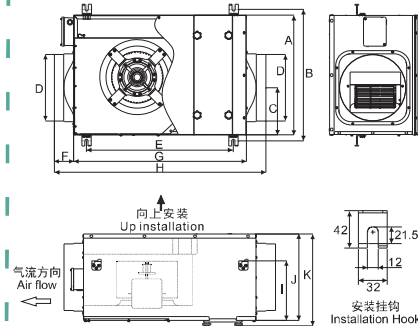

Dimension Table 尺寸表

Units 单位:mm

型号 Model No.	A	B	C	D	E	F	G	H	I	J	K	风口尺寸 Duct Size (mm)
DGT10-24H	315	280	100	95	410	65	459	540	92	120	133	Φ100
DGT15-34H	315	280	120	148	410	65	459	540	132	170	183	Φ150
DGT15-45H	362	327	126	148	460	65	509	590	107	170	183	Φ150
DGT15-55H	445	410	146	148	620	65	666	750	158	220	235	Φ150
DGT20-56H	445	410	146	198	620	65	666	750	158	220	235	Φ200
DGT20-56J	445	410	146	148	620	65	666	750	158	220	235	Φ150
DGT25-56H	450	495	178	248	650	75	553	797	223	325	345	Φ250
DGT25-66H	655	700	218	248	771	75	674	919	232	325	345	Φ250
DGT25-76H	655	700	218	248	771	75	674	919	232	325	345	Φ250

Super-Slim Type Low-Noise Duct Fan (With Filter)

超薄型静音管道风机 (带过滤网)

Electrical Ratings 技术参数

型号 Model No.	额定电压/频率/相数 Rated Voltage/ Frequency/ Phase	风轮直径 Impeller Diameter (mm)	档位 Setting	功率 Power (W)	转速 Rotating Speed (R.P.M.)	风量 Air Volume (m ³ /h)	静压 Static Pressure (Pa)	噪音 Noise (dB(A))	电机绝缘等级 Insulation Class	净重 Net Weight (kg)	
DGT10-24H	220V~/50Hz/1Ph	200	高档 High	40	1339	150	190	44	E	5.5	
			低档 Low	30	1132	120	180	41			
DGT15-34H		200	高档 High	60	1348	250	235	49		6.3	
			低档 Low	51	1174	210	225	44			
DGT15-45H		230	230	高档 High	93	1380	350	270		52	9.0
				低档 Low	72	1209	285	255		50	
DGT15-55H		280	280	高档 High	160	1046	500	350		49	18.0
				低档 Low	110	830	400	300		43	
DGT20-56H		280	280	高档 High	180	896	650	365		49	18.0
				低档 Low	120	713	520	310		43	
DGT20-56J	280	280	高档 High	250	1141	800	380	53	18.0		
			低档 Low	180	921	650	340	47			
DGT25-56H	230	230	高档 High	290	1189	1000	385	60	22.0		
			低档 Low	240	1039	850	350	56			
DGT25-66H	280	280	高档 High	510	1030	1500	500	60	39.0		
			低档 Low	375	837	1200	480	54			
DGT25-76H	280	280	高档 High	820	1345	2000	580	67	39.0		
			低档 Low	670	1159	1750	550	63			

Performance Curve 性能曲线图

- A: DGT10-24H(低档 Low) B: DGT10-24H(高档 High)
- C: DGT15-34H(低档 Low) D: DGT15-34H(高档 High)
- E: DGT15-45H(低档 Low) F: DGT15-45H(高档 High)

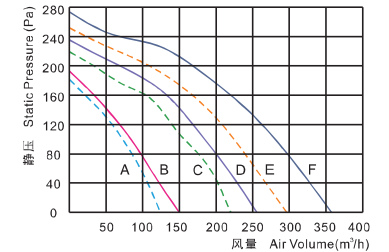

- G: DGT15-55H(低档 Low) H: DGT15-55H(高档 High)
- I: DGT20-56H(低档 Low) J: DGT20-56H(高档 High)
- K: DGT20-56J(低档 Low) L: DGT20-56J(高档 High)

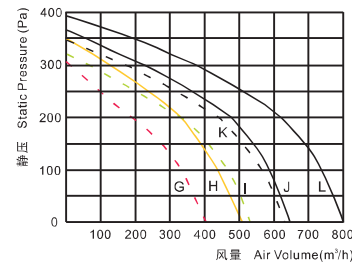

- M: DGT25-56H(低档 Low) N: DGT25-56H(高档 High)
- O: DGT25-66H(低档 Low) P: DGT25-66H(高档 High)
- Q: DGT25-76H(低档 Low) R: DGT25-76H(高档 High)

